



www.futureenergy.co.uk

Welcome to the future, and our latest renewable energy products...

Our 'rugged' **Horizontal Axis Wind Turbine** range first came to market in Spring 2005. Since then we have supplied and installed over 4,000 systems, all over the World.

The specially developed Permanent Magnet Generator, furling tailfin and our five blade (1.75 meter) configuration, enable our turbines to create very useful power in low wind conditions, and over 1000W in winds of 12.5m/s.

Available in 12V (600w), 24V & 48V DC versions, they are suitable for battery charging, water/air heating and Grid-Tie installation. We stock and supply the components to build a complete system for any application.

Weighing in at only 22 kilos our turbines are tower-top ready, and will fit on to a standard 50mm steel tube pole. We don't recommend 'building-mounted' installations other than steel-framed buildings.

All instructions will be supplied to guide you through the simple assembly and you should be ready to mount and use your turbine in only a few hours.

For site location and tower mounting options, please visit www.futureenergy.co.uk, where you will find loads of useful information about setting-up, connecting and operating your turbine.

GRID-TIE SOLUTION

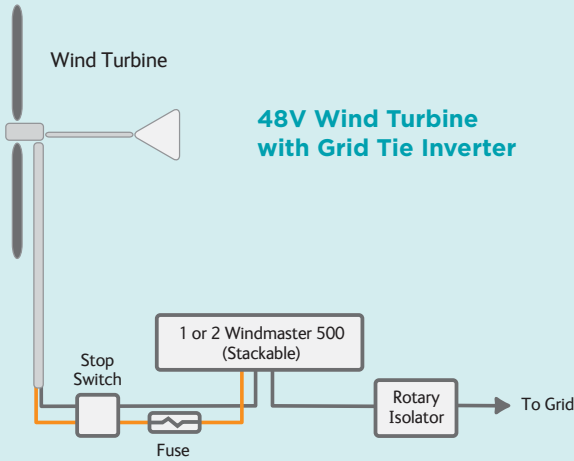

GRID-TIE INVERTER

Windmaster 500 Grid-Tie Inverter - The Windmaster 500 offers a simple solution when connecting an FE1048 turbine to your household mains supply. With its light weight and compact size, the Windmaster 500 can be installed inside existing meter cupboards, or in outbuildings, but is not suitable for use outdoors. Connection to the input of the inverter is provided by 2 dedicated DC power plugs, supplied. The output should be connected in accordance with the electrical requirements for the country of installation.

This inverter comes complete with DC input plugs, PC-Link connection and Monitoring/Logging software. In low wind sites it is advisable to use only one inverter with the FE1048, since over 90% of the power produced by the turbine will lie under the 500W export power limit of the inverter. For higher wind speed sites, we would suggest using 2 inverters, connected in parallel, to handle the full power of the FE1048 turbine. No charge controller is required when using these inverters, since they can handle a much higher input voltage than the turbine can produce, even in power-cut situations.

In "Hybrid" systems (those involving both wind turbines and solar PV), use the standard Soladin 600 inverter for solar, keeping the installation simple and very neat.

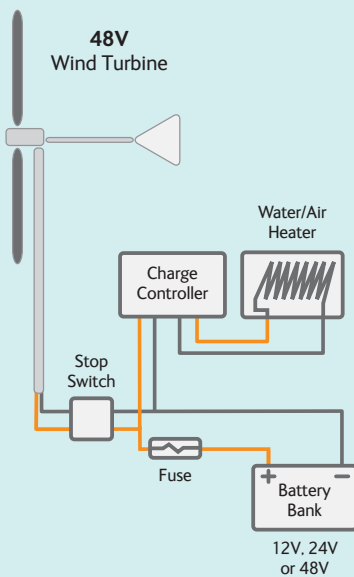

Wind Turbine connected as a Water/Air Heater

WATER/AIR HEATING SOLUTION

IMMERSION HEATER

1000w 48 volt immersion heater. This can be used in a water heating application in preference to dumping any excess energy from the battery into the air with a standard dumpload. The heating element is 12" long and also has a 7" copper pocket. It connects to the tank via a 2.25" BSP thread. Connections are made via a domestic terminal cover.

This product has been specially designed to work with alternative energy water heating applications.



OFF-GRID SOLUTION

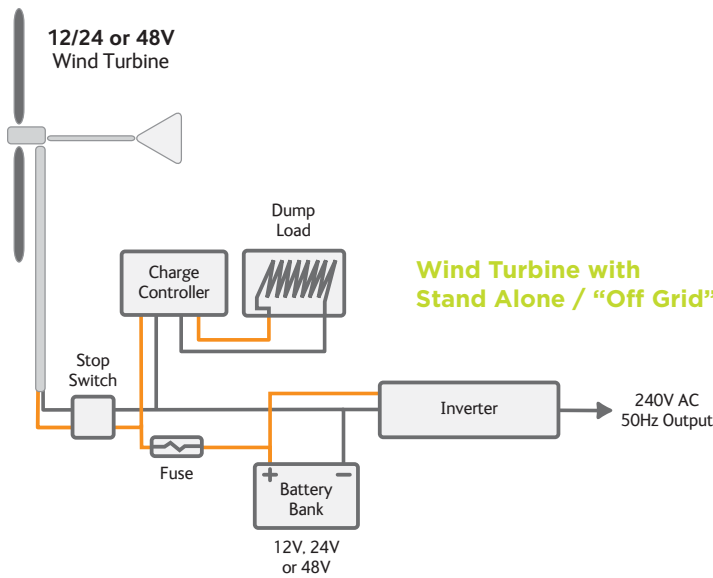

Wind Turbine with Stand Alone / "Off Grid" System



CHARGE CONTROLLER

Xantrex C40 & C60 Charge Controllers -

For use in Battery-Based systems, these rugged charge controllers offer protection against overcharging when used with our FuturEnergy wind turbines. The **Xantrex C60** is capable of handling charging currents of 60A, and is suitable for use with battery banks of 12V and 24V only. The **C40** can handle charging currents of up to 40A, and is suitable for use in 48V battery charging applications.

In order to use either of these controllers with your FuturEnergy Turbine and Battery Bank, you will require a suitable dump load for connection to the C40 or C60

STOP SWITCHES

Stop Switch, DC & AC Isolators - For use with all turbine models, these switches allow the user to isolate the DC supply to a load, to apply an electrical "brake" to the turbine and to isolate the AC side of an inverter (if connected). The AC isolator is a 4-pole 20A lockable switch, which should be used when connecting Grid-Tied Inverters to a "mains" supply. The switch should be mounted close to the main consumer unit, between a spare 16A breaker and the inverters.

The DC Isolator and Brake should be connected to the output of the wind turbine, between it and the load (inverter, batteries etc). The main rotary switch is rated at 63A and is 4-pole. In this mode, the internal connections have been pre-wired in pairs of 2 poles, giving a massive switching capacity of 120A. Also mounted inside these switches are a low resistance "dump load", allowing the turbine to slow to a safe level before applying a direct "short circuit" to the turbine output wires.



DUMP LOAD

For use with either of the Xantrex charge controllers above, these dump loads are effectively very high power air heating elements. The C40 and C60 charge controllers are used in 'Load Diversion' mode, and as such, they dissipate any unwanted power into these dump loads when your battery bank becomes fully charged. It is vital to use a charge controller to prevent damage to your batteries, especially if you leave your system unattended for long periods of time and without loading your batteries with an inverter, or other suitable device.

The following number of dump loads are required with each of the following battery voltages :

- For 12V systems use a C40 or C60 and 2 Dump Loads (in parallel)
- For 24V systems use a C40 or C60 and 1 Dump Load
- For 48V systems use a C40 and 2 Dump Loads (in series)



HIGH POWER CABLE

For use with our turbines and PMG's, this cable is very flexible, High-Power with a 10sq mm conductor area (8 AWG), available in Red or Black. Ideal for connecting the DC power output from our turbines, down your tower to your batteries, charge controller, heating element or inverter. Also good for making your battery bus bar connections.

The cable is sold per meter, and has the following specifications...

- Single core PVC insulated High-Power cable, ideal for use with wind turbines, batteries, power interconnections, charge controllers and heating element connections
- Each cable contains 80 x 0.4sq mm plain annealed copper conductors with heat resisting PVC insulation rated up to +105 oC
- UL, AWM, CSA, TEW, BS6231 and SEMCO recognised
- Maximum working voltage: 600 Volts
- 10sq mm overall conductor area, suitable for currents up to 75A
- Volt drop of only 2.2mV/A/m
- Weight 1.2Kg per 10m

FUTUREENERGY TOWER KIT



Our tower kit is designed to be strong and easy to assembly. With the use of special ground anchors no concrete or foundations are required and the tower can be relocated if required.

The kit comprises of all the components (excluding standard galvanized scaffolding tube*) required to raise your 1 kW FuturEnergy wind turbine (not supplied with the tower kit) to a maximum height of 8 meters. The kit includes Spirafix Ground Anchors that have been specified to meet the required loading capacity calculated from EN-61400 to withstand 50-year maximum wind speeds when installed in most ground conditions**. The kit also includes tube couplings, galvanized wire rope assemblies with tensioners, brackets and full instructions for assembly.

*Galvanized scaffolding tube (48.5mm O/D x 5mm Wall) is available from builders merchants. 2X 3m and 1 X 2m lengths are required for the maximum 8m height.

**Please visit www.spirafix.com/further_info_load_chart.htm for soil type suitability. Anchor type is 50mm x 750mm long and the required loading per anchor is 3.0 kN.



POWER PREDICTOR 2.0

Ever wondered . . .

- How much green energy YOU could generate at your home or business?
- How much money YOU could save off your energy bills?
- How much this would reduce YOUR CO2 emissions?

The Power Predictor answers these questions simply, quickly and easily:

- The Power Predictor assesses the suitability of your site for renewable energy, specifically solar and wind.
- The Power Predictor allows you to cheaply and easily collect real life solar and wind data from your site.
- The Power Predictor produces customised power reports for your site including carbon savings and annual energy generation estimates.
- The Power Predictor tells you how much money you could save by installing the major wind turbines or solar panels on the market before you buy, avoiding expensive mistakes.



Unique Features

- Mechanically furling tail fin for high wind protection
- Unique high-spec Permanent Magnet Generator
- 5 top-grade glass filled nylon turbine blades
- Sealed bearings in mast-mounting shaft
- 60 Amp rated slip-ring prevents cable-twisting
- Aerodynamic profile design
- Rugged and simple, with a minimum of parts and simplicity of design
- Zinc-plated and Stainless Steel with powder-coated and anodised aluminium for optimal corrosion and weather resistance
- Designed & Manufactured in the UK



Technical Specifications

Nominal Power Output - 1000W (600W / 12v Version)

Start-Up Wind Speed - 2.5m/s

Cut-In Wind Speed - 3.2m/s

Rated Wind Speed - 12.5m/s

Survival Wind Speed - 50m/s

Rotor Diameter - 1.8m

Number of Blades - 5

Generator Type - 3-Phase Perm Magnet
(this is rectified to DC inside the turbine, giving a 2-wire DC output)

Weight - 22Kgs

Suitable Tower Diameter - 50mm

Noise - LAeq 35dB @ 5m/s @ 5m behind rotor

Noise - LAeq 54dB @ 7m/s @ 5m behind rotor

ROHS compliant



Performance Data

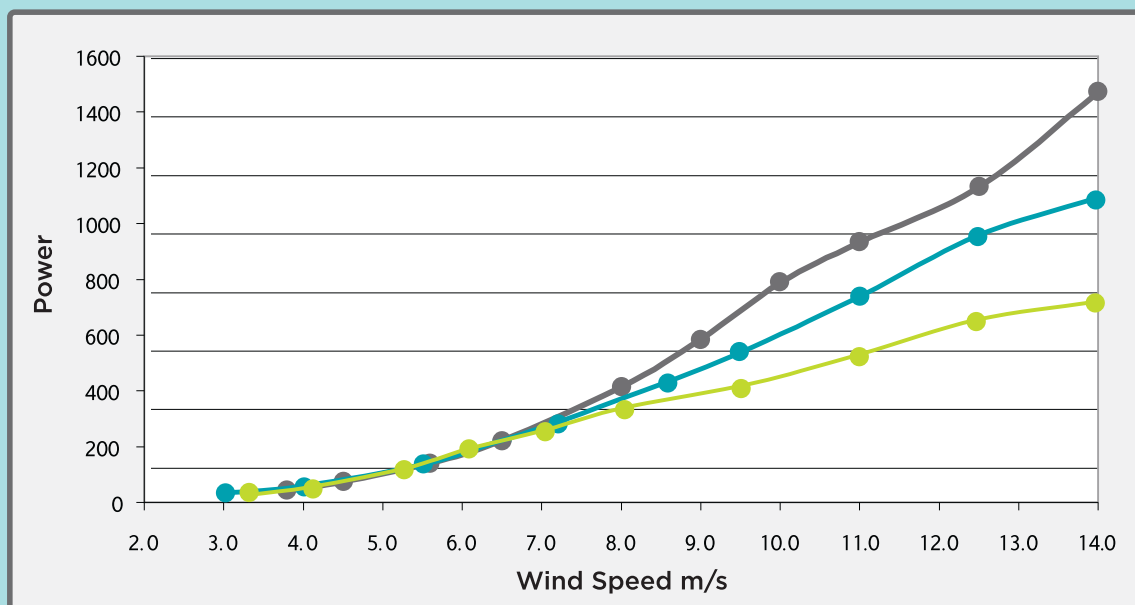

48v 1000w

24v 1000w

12v 600w

WIND TURBINE BLADE SETS

These wind turbine blade sets are constructed to the highest of standards, and are used at the heart of our 1KW downwind range. They can easily be adapted to suit other turbines, and will produce up to 1.2kW of power in 12.5m/s winds. The blade set comes in kit form, including 5 x high-spec blades, manufactured in black PAG material (virtually indestructible, and don't require painting), with 2 x 5-blade hubs (black anodised finish) and location pitch pins (21 degree root angle).

Once assembled, the complete rotor, measuring 1750mm in diameter, can be adapted to suit many power generators, and will perform best in the 300 to 900 RPM range. The hub is supplied with enough nuts & bolts to assemble the complete rotor, and has 5 mounting holes, each of 6mm in diameter, positioned in a pentagon shape at a PCD of 90mm. The main boss hole in the hub has a diameter of 74.6mm, and care should be taken to accurately, securely and centrally mount the completed rotor on to your intended application.

In order to achieve the best results from these blades, the final rotor assembly should be balanced by the user prior to being used in any application. Neither FuturEnergy Ltd nor the blade manufacturers accept any responsibility for any issues arising from unbalanced rotors in any application. Each blade set will be supplied with instructions on how to perform a 'static balance' of the assembled rotor, and it is the user's responsibility to ensure that every effort has been made to address any balancing issues prior to using these blades.



PERMANENT MAGNET GENERATORS

At the heart of our 1KW Turbines is this Permanent Magnet Generator. Using the very latest in rare earth magnets we are able to produce very high power outputs at low RPM levels, while achieving this from a PMG weighing only 7Kg. With a wide variety of uses, from wind and water turbines, to fuel-powered generators, we are offering these PMG's to anyone who wishes to adapt them into their own products.

Supplied with 3-Phase power output cables (approx 15cm in length), 18mm axle securing nut and washer, and 5 x 8mm nuts, washers and split rings on the faceplate mounting bolts. You will need to rectify the output of the 3-phases to produce DC for battery charging and other applications. Our PMG's are not guaranteed for use with your own rectifier solutions, and so we can supply a 3-Phase Bridge Rectifier Kit for this item, please ask when ordering.

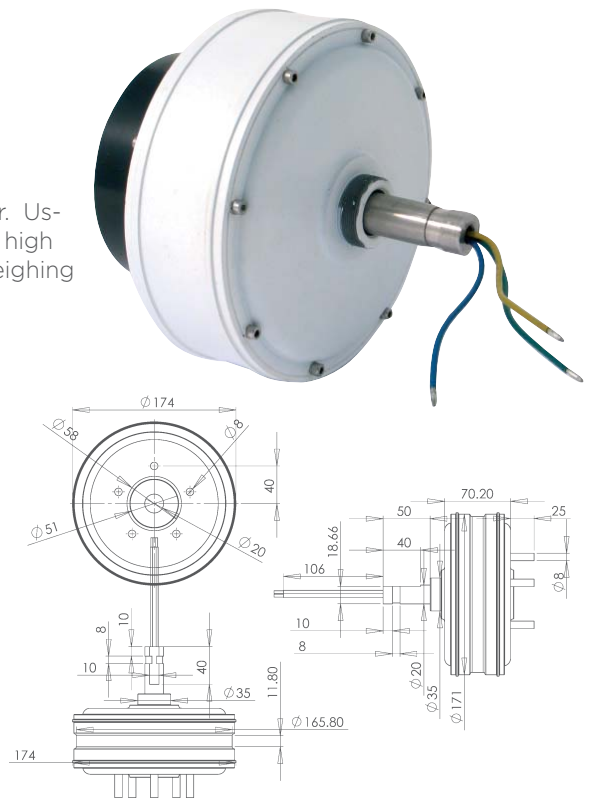

Philosophy

Our development of the very latest in cost-effective products has been driven by the vast renewable resources available to everyone and which remains untapped for most.

We seek to find the best sources of energy and to build and promote products which can extract it efficiently, while making them available to all.

Based in the UK, we work alongside some of the renewable industry's pioneering and forward thinking companies pulling a wealth of knowledge and experience together to bring you the latest in energy efficient products and services.

Please check out our website for the latest news on products, press and successful installation stories. www.futureenergy.co.uk

FuturEnergy Ltd

A subsidiary of Special EFX Ltd

Ettington Park Business Centre
Stratford upon Avon CV37 8BT

T +44 (0)1789 450280

F +44 (0)1789 450916

E sales@futureenergy.co.uk

W www.futureenergy.co.uk